



CSDA1DA



Actual product appearance may vary.

CSDA Series digital current sensor, 0.25 A to 1.0 A operate current, through-hole design, logic level sinking output, operates on AC or DC current, pinout style 3 AMP connector

Features

- Digital output
- AC or DC current sensing
- Through-hole design
- Output voltage isolation from input
- Minimum energy dissipation
- Maximum current limited only by conductor size
- Accurate, low cost sensing
- Operating temperature range -25 °C to 85 °C

Potential Applications

- Variable speed drives
- Overcurrent protection
- Ground fault detectors
- Current feedback control systems
- Robotics
- UPS and telecommunication power supplies
- Welding power supplies
- Automotive - Battery management systems
- Wattmeters

Description

Each Honeywell CS series digital current sensor provides a logic level output that changes from approximately V_{cc} to 0.4 volts when the sensed current exceeds the operate point. Each digital sensor will operate on ac or dc current, but the output will turn off at every zero crossing when sensing AC current.

Product Specifications	
Product Type	Digital current sensor
Sensed Current Type	ac or dc
Package Style	Accepts three-pin AMP connector
Output Voltage	0.40 V
Output Current	20 mA
Output Type	Voltage
Release Current	0.08 NI min.
Nominal Operate Current @ 25 °C	0.50 NI
Supply Current	12 mA max.
Supply Voltage	6.0 Vdc to 16.0 Vdc
Response Time	100 μ s
Minimum Operate Current @ 25 °C	0.32 NI
Maximum Operate Current @ 25 °C	0.88 NI

Operating Temperature Range	-25 °C to 85 °C [-13 °F to 185 °F]
Storage Temperature Range	-40 °C to 100°C [-40 °F to 212 °F]
Housing Material	PBT Polyester
Mounting	Screw mounting
Pinout Style	3-pin, AMP connector
Availability	Global
UNSPSC Code	411121
UNSPSC Commodity	411121 Transducers
Series Name	CSDA

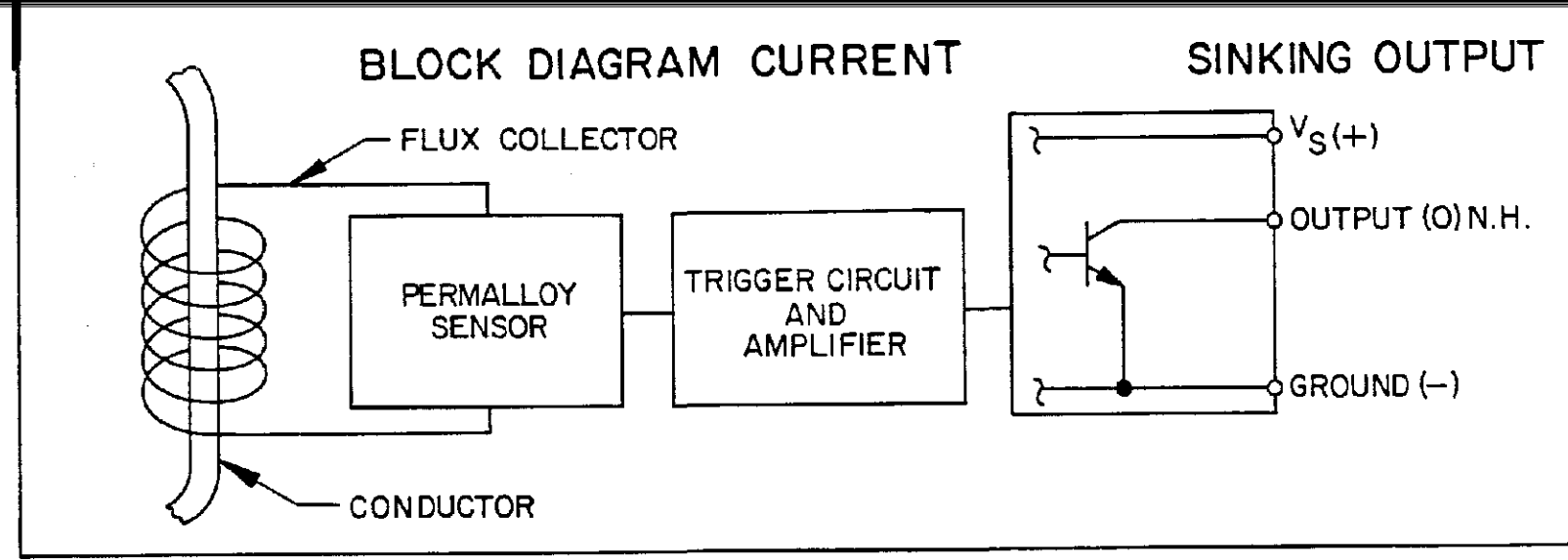
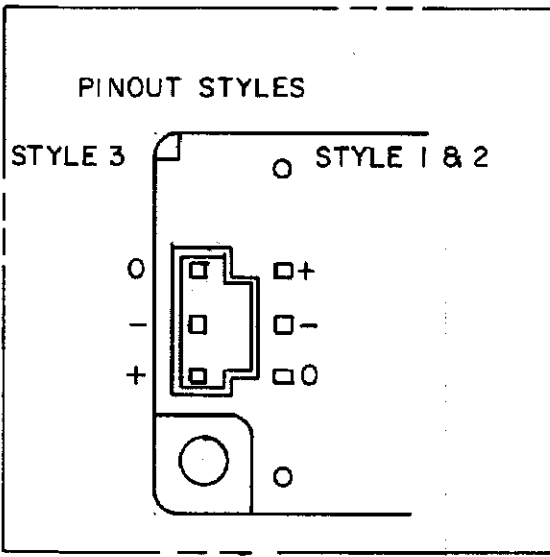
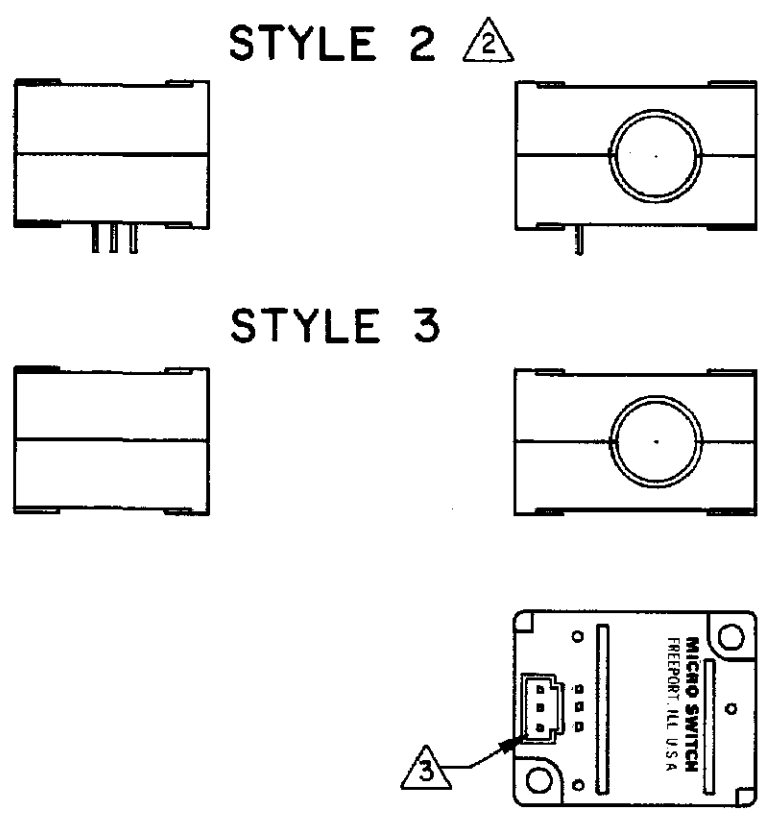
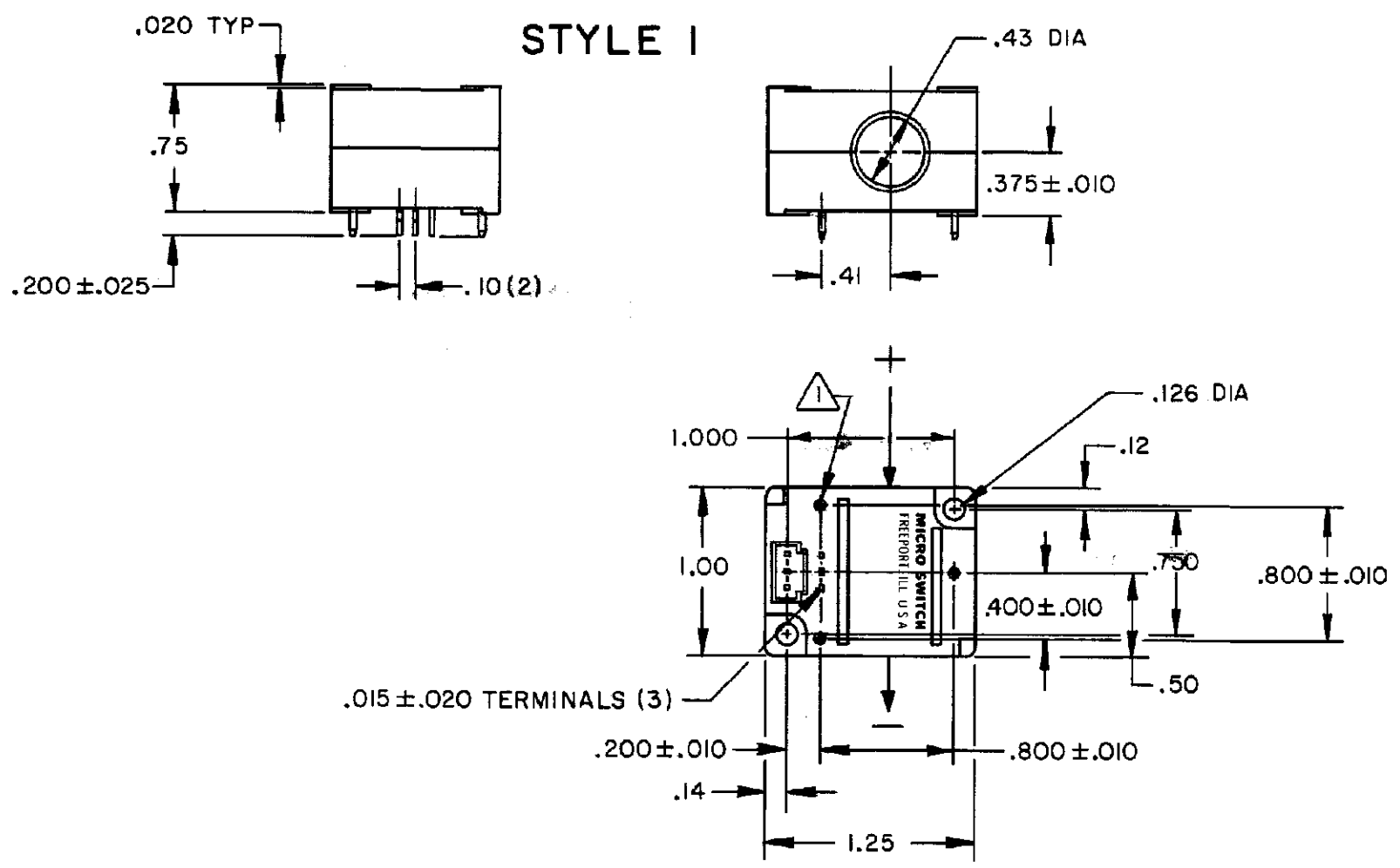

ABSOLUTE MAXIMUM RATING Δ

SUPPLY VOLTAGE (V _S)	24 VDC FOR DEVICE WITH RECOMMENDED V _S OF 6-16 VDC 10 VDC FOR DEVICE WITH RECOMMENDED V _S OF 5±.2 VDC
VOLTAGE EXTERNALLY APPLIED TO OUTPUT	+20.0 VDC MAX. WITH SWITCH IN "OFF" CONDITION ONLY -0.5 VOLTS MIN WITH SWITCH IN "OFF" OR "ON" CONDITION
OUTPUT CURRENT	20mA
TEMPERATURE	-40°C TO +125°C
CURRENT	DEVICE WILL NOT BE DAMAGED BY CURRENT OVER-DRIVE

ELECTRICAL CHARACTERISTICS

	MIN	TYP	MAX	REMARKS
SUPPLY CURRENT (WITHOUT LOAD) Δ		2.5mA	12.0mA 10.0mA	MAX (OPERATED) MAX (RELEASED)
OUTPUT VOLTAGE (OPERATED) Δ		0.26V	0.45V	SINKING 20 mA MAX
OUTPUT LEAKAGE CURRENT (RELEASED) Δ			10 μ A	LEAKAGE INTO SWITCH OUTPUT
OUTPUT SWITCHING TIME (SINKING 8mA) Δ				
RISE TIME		0.2 μ S	1.5 μ S	10% TO 90%
FALL TIME		0.1 μ S	0.5 μ S	90% TO 10%

OPERATE CURRENT (AMP-TURNS) @ 25°C	OPERATE CURRENT (AMP-TURNS) -25°C TO +85°C	RELEASE CURRENT (AMP-TURNS) -25°C TO +85°C	SUPPLY VOLTAGE (V _S)	RESPONSE TIME (μ S) MAX.	C A T A L O G L I S T I N G		
					STYLE 1 Δ	STYLE 2 Δ	STYLE 3 Δ
0.50 ^{+0.38} _{-0.18}	0.50 ^{+0.50} _{-0.25}	.08 MIN.	5±.2	100	Ⓟ	CSDC1BA	CSDC1DA
0.50 ^{+0.38} _{-0.18}	0.50 ^{+0.50} _{-0.25}	.08 MIN.	6-16	100		CSDA1AA	CSDA1DA
3.50 ^{+3.0} _{-1.3}	3.50 ^{+4.0} _{-1.8}	0.6 MIN.	5±.2	100		CSDC1AC	
3.50 ^{+3.0} _{-1.3}	3.50 ^{+4.0} _{-1.8}	0.6 MIN.	6-16	100		CSDA1AC	CSDA1DC

- NOTES**
- Δ INCLUDES (3) .025 X .025 PINS FOR WAVE SOLDER MOUNTING
 - Δ SCREW MOUNTING
 - Δ ACCEPTS CONNECTOR EQUIVALENT TO AMP PART # 102241-1
 - Δ AT RATED SUPPLY VOLTAGE AND OVER A TEMPERATURE RANGE OF -25°C TO +85°C
 - Δ AT A TEMPERATURE OF 24±2°C AND A SUPPLY VOLTAGE OF 5 VDC ± 0.5% FOR 5±.2 VDC RATED DEVICES OR 16 VDC ± 0.5% FOR 6-16 VDC RATED DEVICES
 - Δ ABSOLUTE MAXIMUM RATINGS ARE THE EXTREME LIMITS THAT THE DEVICE WILL WITHSTAND WITHOUT DAMAGE TO THE DEVICE. HOWEVER, THE ELECTRICAL CHARACTERISTICS ARE NOT GUARANTEED AS THE MAXIMUM LIMITS (ABOVE RECOMMENDED OPERATING CONDITIONS) ARE APPROACHED
 - Δ OPERATING CURRENT SPECIFICATIONS ARE FOR CONVENTIONAL CURRENT FLOW IN THE INDICATED DIRECTION. WITH CONVENTIONAL CURRENT FLOW IN THE OPPOSITE DIRECTION, THE OPERATING CURRENT WILL CHANGE. ALSO, FOLLOWING A CURRENT REVERSAL, THE NEXT FEW OPERATIONS IN THE FORWARD DIRECTION MAY HAVE A MINOR SHIFT IN OPERATE POINT
 - Δ EXPOSURE TO LARGE STRAY MAGNETIC FIELDS COULD EFFECT THE OPERATING CURRENT

DRAWING NUMBER: CSD SERIES CHART 1
 PAGE 1 OF 1
 RELEASE NO.: PR-14509
 ISSUE: 7
 REVISIONS:
 A: CO-95704, DLM, 22 MAR 00
 B: 204781, GJW, JAN 02
 C: 205618, GJW, 23 MAY 02
 CHECKED: SAV, 22 MAR 00
 DRAWN: RASTER, DLM, 22 MAR 00



THIS DRAWING COVERS A PROPRIETARY ITEM AND IS THE PROPERTY OF MICRO SWITCH, A DIVISION OF HONEYWELL. THIS DRAWING IS NOT TO BE COPIED OR USED WITHOUT THE APPROVAL OF MICRO SWITCH.

MICRO SWITCH
a Honeywell Division

CATALOG LISTING
CSD SERIES CHART 1

FED. MFG. CODE 91929

THIRD ANGLE PROJECTION

SCALE: FULL

DO NOT SCALE PRINT

UNLESS OTHERWISE SPECIFIED TOLERANCES ARE

ONE PLACE	(.0)	±.030
TWO PLACES	(.00)	±.015
THREE PLACES	(.000)	±.005
ANGLES		±

WEIGHT